



Discover the TMR-3325 XD Advantage

Faster

Quicker turn around time at the delivery site

Flexible

Building materials go right where they are needed

Safer

Less injury risk

Economical

Lower operating costs

TMR-3325 XD sold & serviced by:



Sellick Equipment Limited
358 Erie Street North/P.O. Box 1000
Harrow, Ontario, Canada N0R 1G0
519-738-2255 • sellick@mnsi.net
Visit us at www.sellickequipment.com



TMR-3325 XD
"Shunty" truck mounted
reach forklift



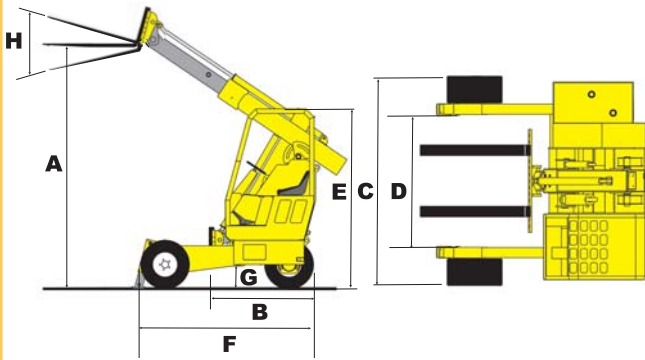

TMR-3325 XD Specifications

Lift Capacity	5500 lbs (2500 kg)
Load Center	24" (500 mm)
Maximum Forward Reach	78" (1970 mm)
Unladen Vehicle Weight	5820 lbs (2640 kg)
Maximum Lift Height (A)	148" (3759 mm)
Overhang (B)	55" (1397 mm)
Overall Width (C)	96" (2440 mm)
Frame Opening (D)	60" (1524 mm)
Overall Height (E)	96" (2392 mm)
Overall Length (F)	90" (2324 mm)
Turning Radius	115" (2921 mm)
Ground Clearance- Laden (G)	12" (305 mm)
Carriage Tilt (H)	114°
Tires	26x12-12, 12 ply
Speed (Forward/Reverse)	7.5 mph (12 km/h)
Gradeability - Laden	35%
Sideshift	8" (203 mm)

Engine

Kubota 4 Cylinder Water Cooled Diesel
50 hp at 2800 rpm

Battery 12 V

Transmission - Hydrostatic

Reversible variable displacement axial piston transmission pump with continuous horsepower, anti-stall and inching control. Fixed displacement radial piston wheel motors. Traction control provided by TPS valve.

Brakes

Service/dynamic braking provided by hydrostatic transmission. Fail-safe oil immersed multi-disc parking brake on front wheels. Dash activated parking brake is also activated when loss of pressure, loss of power or rupture of hydraulic hose.



"Shunty" Truck Mounted Reach Forklift provides versatility and portability. These all-purpose, rough terrain forklifts make delivery of materials to difficult-to-access job sites a snap. Ready to work in less than a minute, the TMR-3325 XD is quick and easy to mount and dismount from any suitable truck or trailer.

Features & Benefits

Easy to mount and dismount - improves delivery times

Low vehicle weight - maximizes payload

Compact - minimizes overhang length when mounted

Telescopic boom - less maintenance than masted forklifts - no chains or rollers

Extended reach - unloading a trailer from one side provides efficient material handling

Traction control - on demand with automatic disengagement

Operation - easy to maneuver with joystick hydraulic controls

Standard equipment-

- Strobe light
- Work lights
- Backup alarm
- Highway lighting
- Inching control
- Full-time all wheel drive